



**CHUNG PAK**

## Alkaline Manganese Button Cell L1325

### 1 • Scope

The specification is applicable to the “VINNIC” brand Alkaline Manganese Button Cell L1325 supplied by CHUNG PAK BATTERY WORKS LTD.

### 2 • Kind of Products Specified

Name (Designation) : L1325

IEC Designation : 4LR44

### 3 • Technical Specification

3.1 Dimension :

Height (H)	$25.2^{+0}_{-0.8}$	mm
Diameter ( $\phi$ )	$13.0^{+0}_{-0.5}$	mm

3.2 Average Weight : 9.6 g

3.3 Nominal Voltage : 6.0 V

3.4 Nominal Capacity : 178 mAh (Discharge at 27 K $\Omega$  to 3.6 V)

3.5 Typical Discharge Duration : 940 hrs (Discharge at 27 K $\Omega$  to 3.6V)

3.6 Outside Shape Dimensions and Terminals :

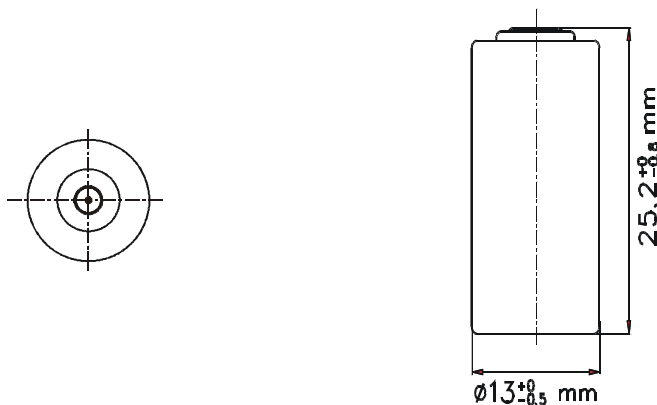



## Alkaline Manganese Button Cell L1325

### 4 • Performance

#### 4.1 Open-circuit Voltage :

Initial	6.2 – 6.6 V
After 12 Months Storage	6.0 – 6.2 V

#### 4.2 Service Out-put :

Load Resistance	27 K $\Omega$
Discharge Method	Continuously
End-point Voltage	3.6 V
Minimum Duration (Initial)	850 Hrs
Minimum Duration (After 12 Months Storage)	800 Hrs

Remark : The word “initial” is applicable to the products elapsed three months or less after production.

#### 4.3 High Temperature Electrolyte Leakage Resistance :

No deformation and no external electrolyte leakage shall be observed.

#### 4.4 Expiry period : One year .

### 5 • Brand and packaging

Any specific design and packing requirements will be accommodated as required.



## Alkaline Manganese Button Cell L1325

### 6. Safety instructions

Warning	Danger
Don't throw the batteries into fire or heat the batteries	This may cause the batteries to ignite or disrupt
Don't directly solder the batteries	This may damage their insulating tapes and protective installation
Don't use the batteries with the $\oplus$ and the $\ominus$ electrode inverse	This can damage the batteries for being over-charged or over-discharged, even may cause leakage, heat generation, disrupt, or ignition
Don't expose the batteries to water	This can cause heat generation or rust
Don't charge batteries	This may result in venting, leakage, explosion and/or possibly fire
Don't disassemble or damage the external tubes of the batteries or modify the batteries (stack-up batteries) etc.	This easily results in short-circuit, leakage, even ignition
Immediately stop using the batteries if leakage, discolor or etc. with them are detected	This may cause accidents to occur
Don't drop or strongly strike the batteries	This may result in leakage, heat generation, disrupt, even ignition
Be sure to use the batteries within a temperature range from 0°C to 40°C	Charge the batteries beyond the temperature range may cause leakage, heat, generation, impaired performance, and shortening of service life of the batteries
Don't use old batteries with new ones	This may cause short-circuit or heat generation
Don't use our batteries with any other type or brand of batteries	Mixed-matching of batteries may result in leakage, heat generation and bursting
Keep the batteries out of the reach of children	To avoid being swallowed. If swallowed, please see doctor immediately



## Alkaline Manganese Button Cell L1325

### *Appendix 1 : Test*

#### **1. Storage and Test Conditions for Samples**

Unless otherwise specified, the storage conditions for samples shall be, as a general rule, at the temperature of  $20\pm 2^{\circ}\text{C}$  and the humidity of  $65\pm 20\%$ .

#### **2. Measuring Instruments**

2.1 Voltmeter : The accuracy of the voltmeter shall be within 0.005V for each 1.5V. The resistance of the measuring instrument shall be at least 10 times the discharge resistance but with a minimum of 1 M ohms per volt of the scale.

2.2 Load Resistance : The load resistance shall include all of the external circuit, and its allowance shall be within  $\pm 0.5\%$ .

2.3 Caliper : The caliper shall be the one having precision of 0.02 millimeters or the one having the same or superior precision to this.

#### **3. Test Methods**

3.1 Dimensions : Measurements shall be made by use of the calipers.

3.2 Appearance : Examination shall be carried out by visual inspection .

3.3 Open-circuit Voltage : Measurements shall be carried out before the start of discharge of the sample by use of the voltmeter .

##### 3.4 Service Out-put

Discharge Start Time : After leaving in an atmosphere at a temperature of  $20\pm 2^{\circ}\text{C}$  for at least 8 hours or more .

Discharge Method : As defined in 4.2 , page 2 .

Discharge End-point : The instant when the closed-circuit voltage has reached below the end-point voltage(as defined in 4.2, page 2).

##### 3.5 High Temperature Electrolyte Leakage Resistance

The following conditions shall be adopted for the test :

(1) Test temperature and humidity :  $45\pm 2^{\circ}\text{C}$  , below 70%RH .

(2) Test period : Leave to stand still 30 days .



## Alkaline Manganese Button Cell L1325

### Appendix 2 : Discharge Characteristics

Standard Discharge Curve :

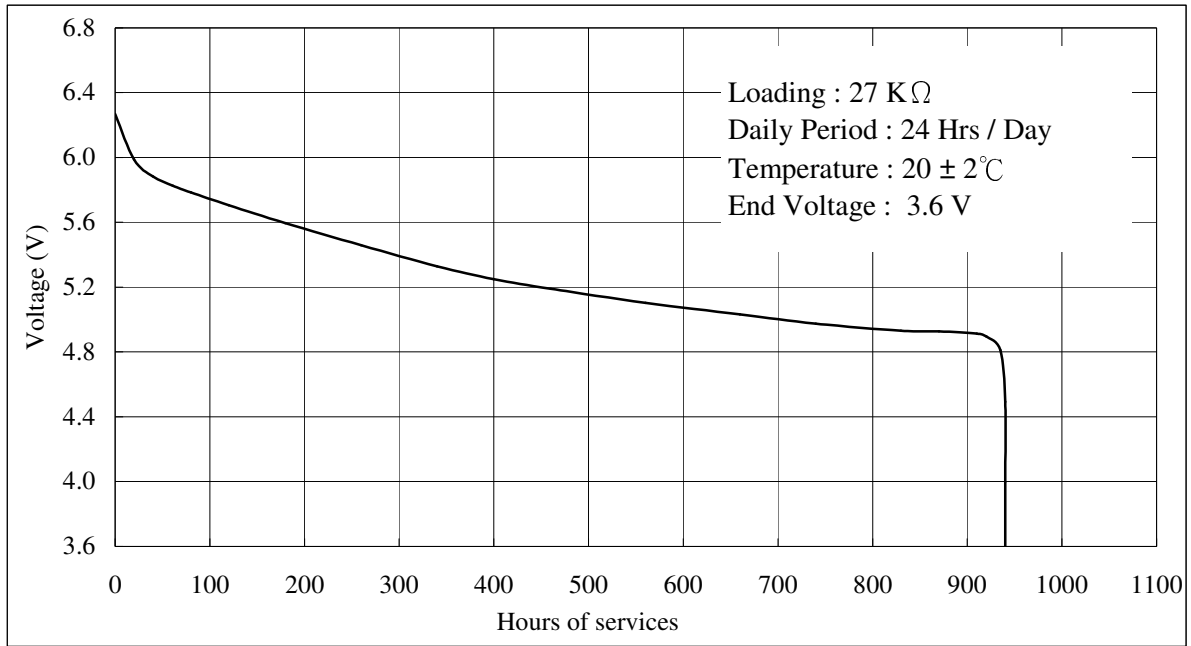

Temperature Characteristic :

