



SPECIFICATIONS
Sealed Rechargeable Nickel Cadmium Button Cell
NI-CD 2500mAh C (High Temperature)

1. SCOPE

The specifications govern the performance of the following Nickel-Cadmium Cylindrical cell and its battery pack. (Refer to the attached figure 1)

Rated capacity: 2500mAh

Designation: NCTC2500 (26/49) (C) (D:25.8⁰_{-1.0}mm H:50.0⁰_{-2.0}mm)



Figure 1- Jacketed cylindrical cells

2. DATA OF BATTERY PACK

The data of battery pack, including voltage and weight, is almost equivalent to the multiple numbers of the relevant single cells.

Example: Battery pack consisting three single cells

Nominal voltage of single cell = 1.2V

Nominal voltage of battery pack = 1.2V×3 = 3.6V

3. RATINGS

Table 1 - Ratings of the cells

Description	Unit	Specification	Conditions
Nominal Voltage	V/Cell	1.2	Single cell
Rated Capacity	mAh	2500	Standard Charge/Discharge

4. PERFORMANCE

Unless otherwise stated, tests should be done within one month of delivery under the following conditions:

Ambient Temperature: 20±5°C

Relative Humidity: 65±20%

Standard Charge/Discharge Conditions:



EVERGREEN (C.P.) USA INC.

TEL: (650) 952-8091 FAX: (650) 952-3629 E-MAIL: sales@evergreencpusa.com

SPECIFICATIONS

Sealed Rechargeable Nickel Cadmium Button Cell NI-CD 2500mAh C (High Temperature)

Preparative: Prior to charging, the cell shall be discharged by **500mA** ($0.2I_t$) to 1.0V

Charge: **250mA** ($0.1I_t$) \times 16hours

Stand in charged condition:1~4h

Discharge: **500mA** ($0.2I_t$) to 1.0V/Cell I

Table 2 – Performance and test methods

Test Item	Unit	Specification	Test Conditions	Remarks	
Discharge performance	20 ℃ ^a	h	≥ 5	Standard Charge/Discharge	/
		min	≥ 48	After Standard Charge, stored for 1~4h, then discharged by 2500mA ($1.0I_t$) to 0.9V.	/
	-18℃	h	≥ 2	After Standard Charge, stored for 16~24h in $-18\pm 2^\circ\text{C}$, then discharged by 500mA ($0.2I_t$) to 1.0V in $-18\pm 2^\circ\text{C}$.	/
Charge (capacity) retention	h/min	$\geq 3\text{h}15\text{min}$	After Standard Charge, stored on open circuit for a period of 28days, then discharged by 500mA ($0.2I_t$) to 1.0V.	/	
Endurance in cycles	cycle	≥ 50	Appendix-table 3	/	
Permanent charge endurance	A: $\geq 3\text{h}45\text{min}$ B: $\geq 42\text{min}$ 2 nd		Appendix-table 4	/	
	A: $\geq 3\text{h}45\text{min}$ B: $\geq 42\text{min}$ 3 rd				
	A: $\geq 2\text{h}30\text{min}$ B: $\geq 24\text{min}$ 8 th				
	A: $\geq 2\text{h}30\text{min}$ B: $\geq 24\text{min}$ 9 th				
Over charge	Discharge A	h/min	$\geq 4\text{h}15\text{min}$	Appendix-table 5	/
	Discharge B	min	≥ 36		
Safety device operation	Not disrupt or burst		Undergo a forced discharge at constant current 500mA ($0.2I_t$) to 0V. Then discharged by 2500mA ($1.0I_t$) for 60min.	/	
Storage ^b	hour	≥ 5	Stored on open circuit for 12 months. Then standard charge/discharge.	/	
Charge acceptance	/	/	IEC 61951-1 2003 7.9	Reference	
Internal resistance	mΩ	≤ 15	Within 1~4h after standard Charge (1000Hz)	Battery pack	
Weight	g	60.0 (approx)	/	Reference	
Vibration	No leakage, no fire, no explosion		IEC 62133 2002 4.2.2	/	
Free fall	No fire, no explosion		IEC 62133 2002 4.3.3	/	

a) Five cycles is permitted b) Unless otherwise stated, the cell shall be discharged by **500mA** ($0.2I_t$) to 1.0V before test.

Notice: Test conditions is drawn according to IEC 61951-1 2003; Please refer to the related description of the standard.

5. CONFIGURATION, DIMENSIONS AND MARKINGS

Please refer to the attached drawing.

6. EXTERNAL APPEARANCE

The cell/battery shall be free from cracks, scars, breakage, rust, discoloration, leakage nor deformation.



SPECIFICATIONS
Sealed Rechargeable Nickel Cadmium Button Cell
NI-CD 2500mAh C (High Temperature)

7. CAUTION

- (1) Reverse charging is not acceptable.
- (2) Charge before use. The cells/batteries are delivered in an uncharged state.
- (3) Do not charge/discharge with more than our specified current.
- (4) Prevent short circuit, do not incinerate or disassemble the cell/battery.
- (5) Do not solder directly to the cell/battery for a long time.
- (6) The life expectancy may be reduced if the cell/battery is subjected adverse conditions like: extreme temperature, deep cycling, excessive overcharge/ over-discharge.
- (7) Store the cell/battery in a cool and dry place. Always discharge batteries before assemble or solder.
- (8) Always discharge batteries before bulk storage or shipment.
- (9) Do not mix batteries of different types and capacities.

Appendix

A) Endurance in cycles

Prior to the endurance on cycle test ,the cell shall be discharged at **500mA** ($0.2I_tA$) to 1.0V. The following test shall be carried out in accordance with the conditions specified in Table 3.

Table 3 Endurance in cycles

Cycle number	Charge	Stand in charged condition	Discharge
1	$0.1I_tA$ for 16h	none	$0.25I_tA$ for 2h20min
2~48	$0.25I_tA$ for 3h10min	none	$0.25I_tA$ for 2h20min
49	$0.25I_tA$ for 3h10min	none	$0.25I_tA$ to 1.0V
50	$0.1I_tA$ for 16h	1h~4h	$0.20I_tA$ to 1.0V ^a
a) Cycles 1 to 50 shall be repeated until the discharge duration on any 50th Cycle becomes less than 3h or the cell voltage drops below 1.0V during 1~48 th cycle.			

B) Permanent charge endurance

The permanent charge endurance test shall be performed in three steps according to the conditions specified in table 4.

It consists of:

- A charge acceptance test at +40°C;
- An ageing period of six months at +70°C;
- A final charge acceptance test to check the cell' s performance after ageing.



SPECIFICATIONS
Sealed Rechargeable Nickel Cadmium Button Cell
NI-CD 2500mAh C (High Temperature)

Cycle number	Ambient temperature	Charge	Discharge A or B ^a	Minimum discharge duration
1	40°C±2°C	0.05I _B A for 48h	A: 0.2I _B A to 1.0V or B: 1.0I _B A to 1.0V	No requirement
2		0.05I _B A for 24h	A: 0.2I _B A to 1.0V or B: 1.0I _B A to 1.0V	3h45min 42min
3		0.05I _B A for 24h	A: 0.2I _B A to 1.0V or B: 1.0I _B A to 1.0V	3h45min 42min
4	70°C±2°C	0.05I _B A for 60d	A: 0.2I _B A to 1.0V or B: 1.0I _B A to 1.0V	No requirement
5		0.05I _B A for 60d	A: 0.2I _B A to 1.0V or B: 1.0I _B A to 1.0V	
6		0.05I _B A for 60d	A: 0.2I _B A to 1.0V or B: 1.0I _B A to 1.0V	
7	40°C±2°C	0.05I _B A for 48h	A: 0.2I _B A to 1.0V or B: 1.0I _B A to 1.0V	No requirement
8		0.05I _B A for 24h	A: 0.2I _B A to 1.0V or B: 1.0I _B A to 1.0V	2h30min 24min
9		0.05I _B A for 24h	A: 0.2I _B A to 1.0V or B: 1.0I _B A to 1.0V	2h30min 24min
a) A: for LT, MT, HT cells; B: for MT, HT cells only.				

C) Over charge

The ability of the cell to withstand an overcharge shall be determined by the following test at 0°C±2°C in circulating air.

The test shall be carried out according to the specified in table 5.

Table 5 Overcharge at 0°C

Charge	Discharge A ^a		Discharge B ^a
	LT, MT, HT cells		MT, HT cells
0.05 I _B A for 28d	0.2I _B A to 1.0V		1.0I _B A to 1.0V
a) The discharge is carried out immediately on the charging			



SPECIFICATIONS
Sealed Rechargeable Nickel Cadmium Button Cell
NI-CD 2500mAh C (High Temperature)

Base Data:

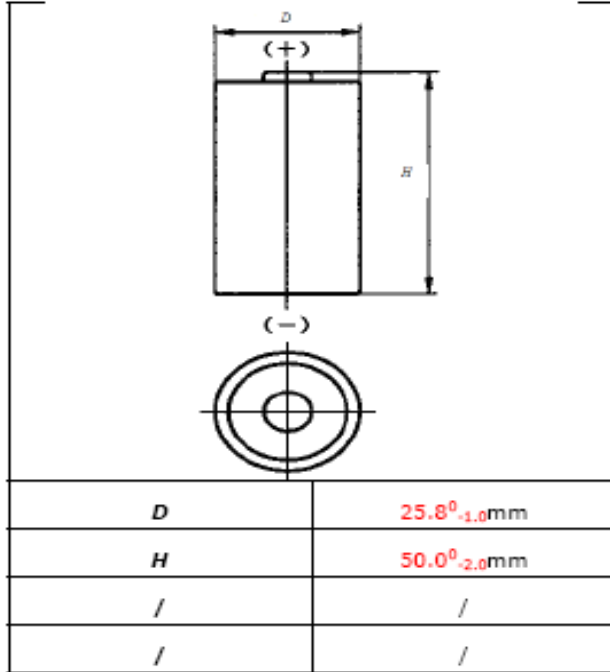

Nominal voltage		1.2V	
Capacity comparison (mAh)	0.2I _c A	2500	
	1.0I _c A	2000	
Weight (g)		60.0	
Internal Impedance at 1000Hz (After Charge Ω)		≤15	
Charge current	Standard	250mA	
	Rapid	2500mA	
Charge time	Standard	16h	
	Rapid	72min, plus 2h by 0.1I _c A	
Temperature Ambient	Charge	Standard	0~+45℃
		Rapid	+10~+45℃
	Discharge		-20~+60℃
	Storage		-20~+35℃

Electrical Performance:

