

SPECIFICATIONS
FOR MANGANESE DIOXIDE LITHIUM BATTERY

CR1220

RECEIVED BY :

Prepared by

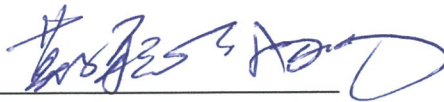

Approved by

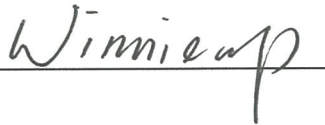

Date : JAN 2017

CHUNG PAK BATTERY WORKS LIMITED

7/F Chung Pak Commercial Building, 2 Cho Yuen Street, Yau Tong Bay,

Kowloon, Hong Kong

TEL: (852) 27171338

FAX: (852) 27727727

E-MAIL: cpgsales@chungpak.com

Website: www.vinnic.com

CHUNG PAK (GUANG DONG) BATTERY INDUSTRIAL CO.,LTD

Gan Cun Section, Fo Chen Road, Chen Cun County, Shun De District, Fo Shan City, Guang Dong
Province, China

TEL: (86 757) 233123338

FAX: (86 757) 23312339

E-MAIL: cpgsales@chungpak.com

Website: www.vinnic.com

Manganese Dioxide Lithium Battery CR1220

1 · Scope

This specification is applicable to the “Vinnic” brand Coin Type Manganese Dioxide Lithium Battery CR1220 supplied by CHUNG PAK BATTERY WORKS LTD.

2 · Technology Parameters

2.1 Model No.: CR1220

2.2 Nominal Voltage: 3.0V

2.3 Dimension :

Height (H)	2.00	⁺⁰ _{-0.20}	mm
Diameter (Φ)	12.50	⁺⁰ _{-0.30}	mm

2.4 Nominal weight: 0.8 g

2.5 Nominal capacity: 36 mAh (Continuously discharged under 62KΩ load till 2.0 V end voltage at temperature of 20 ± 2°C.

2.6 Standard discharge current: 0.048 mA

2.7 Typical discharge duration: 760 hrs (Continuously discharged under 62KΩ load till 2.0 V end voltage at temperature of 20 ± 2°C.

2.8 Operating Temperature: -20°C ~ 60°C

2.9 Storage conditions:

Temperature range: -20°C ~ 60°C

Humidity range: 35% ~ 75%

2.10 The drawing of the finished battery:

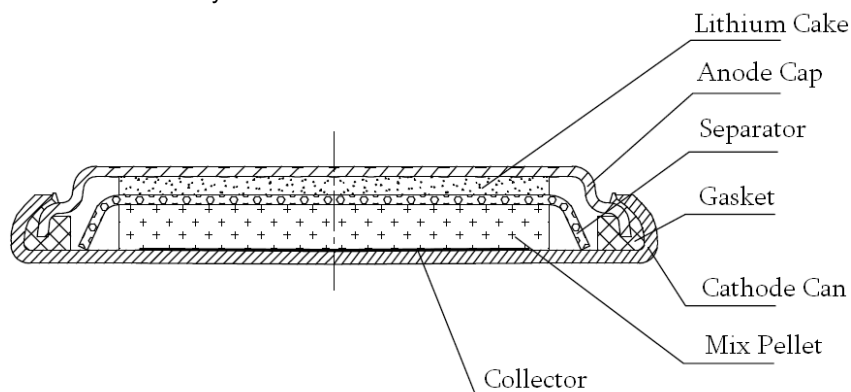

Remark: There is deviation between part shape of “The Finished Battery Drawing” and actual product.

The Drawing of Finished Battery is for reference only.

Manganese Dioxide Lithium Battery CR1220

2.11 Outline shape dimensions and terminals:

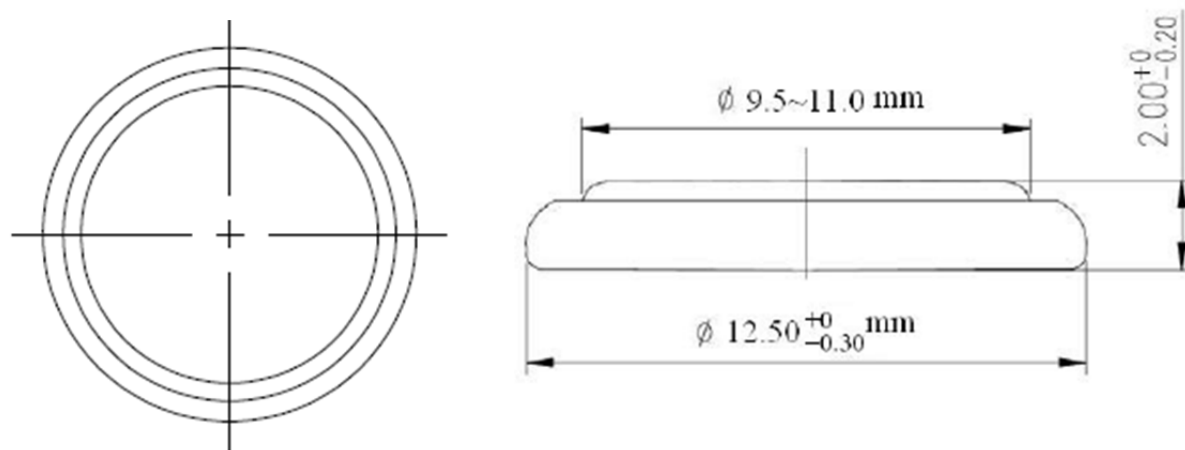

3 · Performance

3.1 Off-load voltage

Temperature	20±2℃	0±2℃	Remarks
Initial	3.13V~3.50V	3.05V~3.50V	Off-load
After 12 months	3.10V~3.40V	3.05V~3.40V	
After 24 months	3.05V~3.35V	3.02V~3.35V	
After 36 months	3.02V~3.30V	3.00V~3.30V	

3.2 On-load voltage

Temperature	20±2℃	0±2℃	Remarks
Initial	3.00V~3.35V	3.00V~3.35V	62KΩ load after 0.8sec.
After 12 months	3.00V~3.35V	3.00V~3.35V	
After 24 months	3.00V~3.30V	3.00V~3.30V	
After 36 months	3.00V~3.25V	3.00V~3.25V	

Manganese Dioxide Lithium Battery CR1220

3.3 Self-discharge characteristics

Reference Requirement	Discharge Condition				Average Minimum duration			
	Load resistance	Discharge method	Temperature	End point voltage (V)	Initial	After 12 months storage	After 24 months storage	After 36 months storage
IEC	62KΩ	Continuous	20±2℃	2.0V	760Hrs	745Hrs	725Hrs*	700Hrs*
REF	62KΩ	Continuous	60±2℃**	2.0V	750Hrs	/	/	/
REF	62KΩ	Continuous	0±2℃	2.0V	750Hrs	/	/	/

“*” : It's REF standard;

“**” : After 20 days storage at the high temperature (60±2℃) and then shall be continuously discharge at 20±2℃ under 62KΩ till 2.0V.

3.4 Resistance to leakage

Test items	Condition	Storage period	Requirement	Remarks
High temp.	60±2℃	30 Days	No leakage	After storage, the battery should be kept at 20±2℃ for 8hrs. (shall be inspected by visual means)
Overdischarge	20±2℃	/	No leakage, no deformation	Continuously discharged under 62KΩ till 1.2V.

3.5 External short circuit

The test batteries shall be stabilized at 55±2℃ and than subjected to a short-circuit condition with a total external resistance of less than 0.1Ω at 55±2℃. This short condition is continued for at least 1 hrs after the battery case temperature has returned to 55±2℃. There is no explosion, no fire.

3.6 Expiry period : Three years.

Manganese Dioxide Lithium Battery CR1220

4 · Brand and packaging

4.1 Appendix 1:Standard and packaging

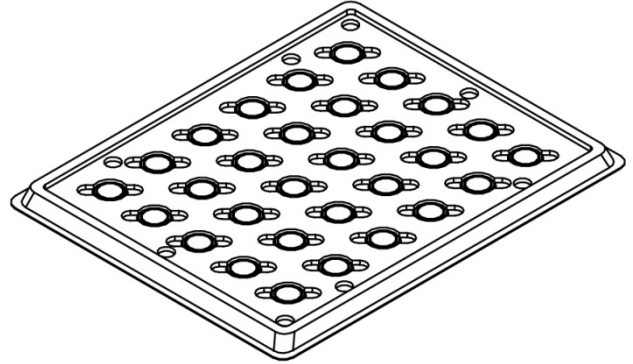

Manganese Dioxide Lithium
Battery CR1220

30 Pcs Per Display Pallet

White Insulate Pallet Measure :170X136X6.25 mm

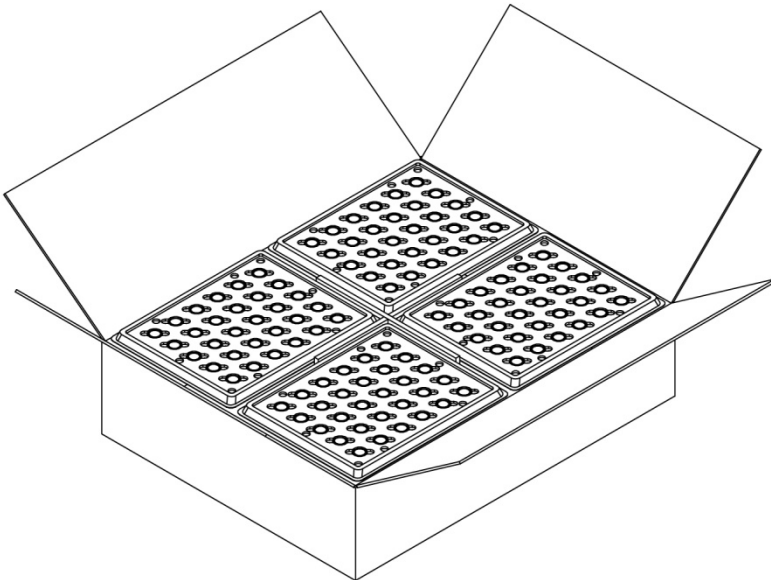

3000 Pcs Per Display Carton

Carton Measure:35.5X28.2X10.9 cm

4.2 Both OEM and ODM orders are welcome. Any specific design and packing requirements will be accommodated as required.

Manganese Dioxide Lithium Battery CR1220

5 · Testing

5.1 Initial test

Means the test begin in three months or less after production.

5.2 Test conditions for Samples

Unless otherwise specified, the test conditions for samples shall be, as a general rule, at the temperature of $20\pm 2^{\circ}\text{C}$ and the humidity of $55\pm 20\%$.

5.3 Measuring instruments

5.3.1 Voltmeter : The accuracy of the measuring equipment shall be $\leq 0.25\%$ and the precision shall be $\leq 50\%$ of the value of the last significant digit. The internal resistance of the measuring instrument shall be $\geq 1\text{M}\Omega$.

5.3.2 Load resistance : The load resistance shall include all of the external circuit, and its allowance shall be within $\pm 0.5\%$.

5.3.3 Caliper : The caliper shall be the one having precision of 0.02minimeters or the one having the same or superior precision to this.

5.3.4 Electrical drying box: Tolerance shall be $\pm 2^{\circ}\text{C}$ or below.

5.4 Test methods

5.4.1 Dimensions :

Dimension shall be measured with instruments specified in subparagraph 5.3.3 above, provided that either one or both side of such instruments shall be insulated in measuring the overall height of the batteries.

5.4.2 Appearance : Examination shall be carried out by visual inspection .

5.4.3 Off-load Voltage :

The specimen batteries shall be kept for 8 hours or longer at the ambient temperature specified in 5.2, and than the voltage between both terminals shall be measured at the same ambient temperature with a voltmeter as specified in subparagraph 5.3.1.

5.4.4 On-load voltage :

The specimen batteries shall be kept for 8 hours or longer at the ambient temperature specified in 5.2, and than the voltage between both terminals shall be measured with a voltmeter as specified in subparagraph 5.3.1 while the specified load is connected between both terminals at the same ambient temperature as specified above; provided that the measured value shall be based on meter reading taken 0.8 seconds after the circuit is closed.

Manganese Dioxide Lithium Battery CR1220

5.4.5 Service life :

Test specimen batteries shall be kept for 8 hours or longer at the ambient temperature specified in 5.2, and shall then be continuously discharged at same ambient temperature and through the specified load resistance. The discharge shall be continued until the terminal voltage of 2.0V, and the time during which the terminal voltage has been maintained equal to and above the discharge end-point voltage shall be taken as the service life.

5.4.6 Service life at high-temperature storage :

Test specimen batteries, after having been stored at the temperature and period specified in 3.3, shall be kept for 12 hours or longer at ordinary temperature ($20\pm 2^{\circ}\text{C}$) and at ordinary humidity ($55\pm 20\%\text{RH}$) and shall then be continuously discharged through the load resistance $62\text{K}\Omega$ at ambient temperature of $20\pm 2^{\circ}\text{C}$. The discharge shall be continued until the voltage falls below the discharge end-point voltage of 2.0V, and the time during which the voltage has been maintained equal to and above the discharge end- point volt age shall be taken as the service life.

5.4.7 Self-discharge :

Test specimen batteries which have been stored for 12 months at the ambient temperature of $20\pm 2^{\circ}\text{C}$ and at the relative humidity of $55\pm 20\%$ shall be tested for service life in accordance with the method specified in subparagraph 5.4.5.

Self discharge shall be determined in the following manner:



$$\text{Self-discharge rate (\%)} = \frac{X_1 - X_2}{X_1} \times 100\%$$

X_1 : Average initial discharge life of batteries of the same lot.

X_2 : Average discharge life after storage

Manganese Dioxide Lithium Battery CR1220

6 · Safety instructions

Warning	Danger
① Don't throw the batteries into fire or heat the batteries.	This may cause the batteries to disrupt or ignite.
② Don't directly solder the batteries.	This may damage their insulating tapes and protective installation, even may cause leakage, explosion and fire.
③ Don't insert and use batteries with the  &  electrode inverse.	This can damage the batteries for being force charged, even may cause leakage, heat generation , disrupt, explosion or ignition.
④ Don't short-circuit the positive and negative terminals of a battery.	This may cause heat generation, leakage, explosion, fire and personal injury.
⑤ Don't expose the batteries to water.	This can cause heat generation or rust.
⑥ Don't charge and force discharge batteries.	This may cause leakage, heat generation, even explosion and ignition.
⑦ Don't disassemble or damage the external tubes of the batteries or modify the batteries(stack-up batteries) etc.	This easily results in short-circuit, leakage, even ignition.
⑧ Store unused batteries in their original packaging away from metal objects.	This can cause battery short-circuiting which may result in venting, leakage, and explosion and personal injury.
⑨ Don't crush, puncture, or otherwise mutilate to deform batteries.	This may cause venting, leakage, explosion and personal injury.
⑩ Immediately stop using the batteries if leakage, discolor or etc. with them are detected.	This may cause accidents to occur.
⑪ Don't drop or strongly strike the batteries.	This may result in leakage, heat generation, disrupt, even ignition.
⑫ To avoid using at high temperature and high humidity ambient.	This may cause batteries early damage.
⑬ a. Be sure to use the batteries within a temperature range from 0℃ to 40℃. b. Be sure to storage the batteries within a temperature range at 20±5℃.	a. Use the batteries beyond the temperature range may cause leakage, heat generation, impaired performance, and shortening of service life of the batteries. b. Storage the batteries beyond the temperature range may cause heat generation, impaired performance, and shortening of service life of the batteries.
⑭ Don't use old batteries with new ones.	Some batteries may be over-discharged. This can result in venting, leakage, explosion and personal injury.
⑮ Don't use our batteries with any other type or brand of batteries.	Mixed-matching of batteries may result in heat generation, leakage, explosion, fire.
⑯ Remove batteries from equipment if it is not to be used for an extended period of time.	When batteries beyond expiry period, electrolyte leakage may occur causing damage to the equipment.
⑰ Exhausted batteries should be immediately removed from equipment.	When discharged batteries are kept in the equipment for a long time, electrolyte leakage may occur causing damage to the appliance and/or personal injury.
⑱ Keep the batteries out of the reach of children.	To avoid being swallowed. If swallowed, Please see doctor immediately.
⑲ Don't allow children to replace batteries without adult supervision.	This may cause wrong operation, even may occur accident.
⑳ Please use batteries within expiry period.	To avoid using invalid batteries which beyond expiry period
㉑ Don't take batteries by hand directly. Please wear finger cots.	This may cause rust.
㉒ Don't take batteries with iron tweezer. Please use plastic tweezer.	This can cause battery short-circuiting which may result in heat generation , leakage, and explosion.

Manganese Dioxide Lithium Battery CR1220

Appendix : Discharge Characteristics

Standard Discharge Curve:

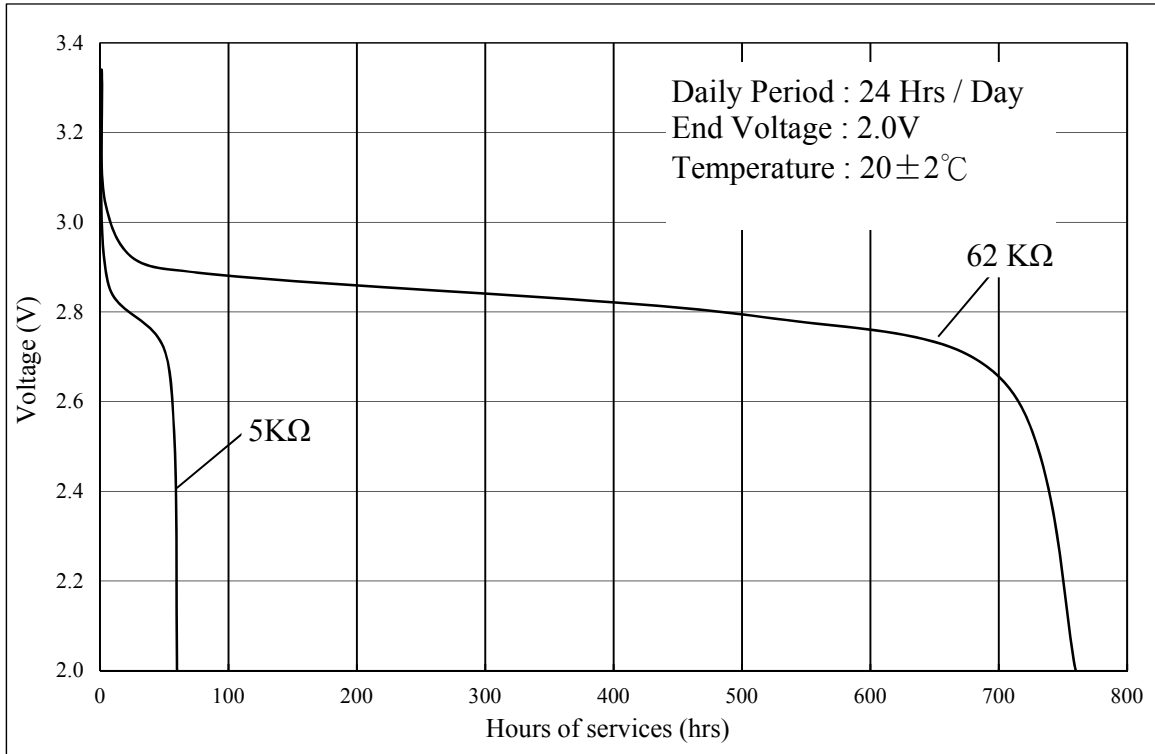

Temperature Characteristic:

